



✓ Urgent Up-Skilling

Introduction to Digital Twins as a tool to promote Sustainability



Co-funded by
the European Union



Introduction to Digital Twins as a tool to promote Sustainability

The aim of the course was to present this digital tool as an opportunity to optimize and therefore make some processes more sustainable through two specific examples such as water management or the manufacture of concrete elements.

 Urgent Up-Skilling

This course is provided by:

unir LA UNIVERSIDAD
EN INTERNET

January, 2025

Agenda

1. Introduction and overview on the project Digital4Sustainability
2. Digital Sustainability in Industry - Roberto Moreno
3. Digital Twins and Model Based System Engineering (MBSE) - Iván Pena
4. Use case 1: Digital Twins for a Water Treatment Plant- Carlos Rodríguez
5. Use Case 2; Digital Twin for additive manufacturing of mortars - Carlos Real
6. Q&A and Contest Winner
7. Evaluation and closing





Meet the speaker

Dr. María Dolores Cima Cabal

Academic Director, UNIR

<https://www.linkedin.com/in/dolores-cima-15046633/>

Introduction and Overview of the project D4S



Digital4Sustainability – Accelerating the Digital & Green Transition in the ICT Industry

- Programme: ERASMUS-EDU- 2023-PI-ALL-INNO-BLUEPRINT Alliances for Sectoral Cooperation on Skills.
- 4-years transnational initiative funded by the European Commission and counting on

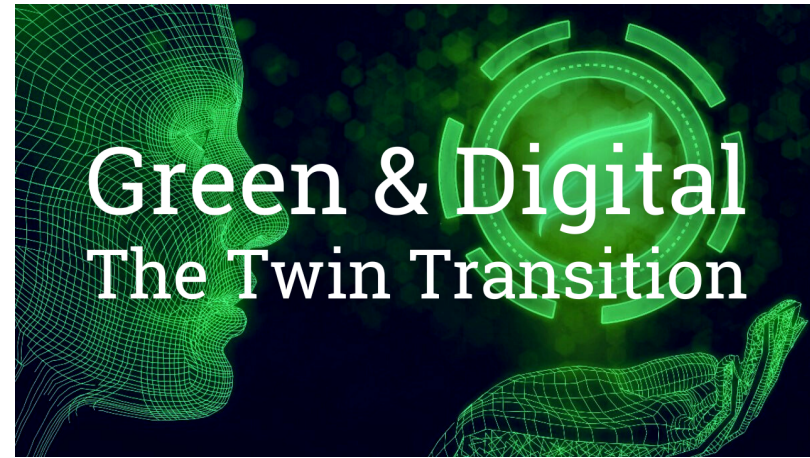

<https://www.linkedin.com/pulse/green-digital-twin-transition-justin-anderson/>

Digital4Sustainability – Accelerating the Digital & Green Transition in the ICT Industry

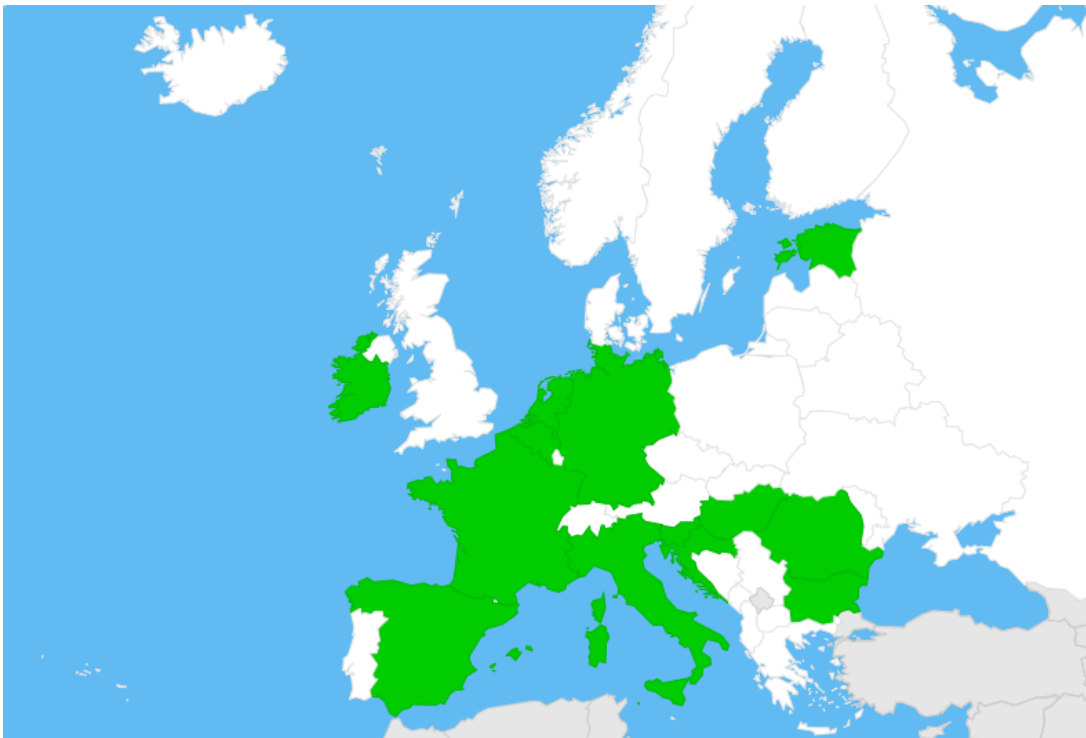

- The Consortium includes digital sustainability experts, business associations, universities and education and training providers coming from: Belgium, Bulgaria, Croatia, Estonia, France, Germany, Hungary, Ireland, Italy, Rumania, Slovenia, Spain, the Netherlands.

Digital4Sustainability – Accelerating the Digital & Green Transition in the ICT Industry

Digital4Sustainability is a project funded under the Erasmus+ programme, dedicated to accelerating the digital and green transitions within the ICT sector and across European industries. Our mission is to develop and implement innovative training programmes that provide professionals and businesses with the skills and knowledge needed to thrive in a rapidly evolving landscape where digital technology and sustainability intersect.



https://joint-research-centre.ec.europa.eu/jrc-news-and-updates/twin-green-digital-transition-how-sustainable-digital-technologies-could-enable-carbon-neutral-eu-2022-06-29_en

Digital4Sustainability – Accelerating the Digital & Green Transition in the ICT Industry

In order to contribute to the Net Zero strategy, the project will develop a set of digital sustainability skills through learning programmes that will respond to the urgent and emerging needs of European industry, thus supporting environmental, social and governance sustainability.



https://joint-research-centre.ec.europa.eu/jrc-news-and-updates/twin-green-digital-transition-how-sustainable-digital-technologies-could-enable-carbon-neutral-eu-2022-06-29_en

Digital4Sustainability – Accelerating the Digital & Green Transition in the ICT Industry

- D4s is developed withing the framework established by the Coalition for Digital Environmental Sustainability (CODES)
- CODES believes in the assumption that digitisation will be crucial to reach the Sustainable Development Goals.
- An assessment carried out in 2020 demonstrated that the 70% of the 169 objectives of the SdGs can be more easily achieved through the use of digital technologies



Digital4Sustainability – Accelerating the Digital & Green Transition in the ICT Industry

- CODES Action Plan: based on 3 shifts and 18 strategic priorities to achieve a sustainable planet in the digital era:
 - ✓ Enable Alignment of vision values and objectives
 - ✓ Mitigate negative impacts of sustainable digitalisation
 - ✓ Accelerate innovation with digitalisation for sustainability



D4S Target groups



Foreseen activities (WorkPackages-WPs)

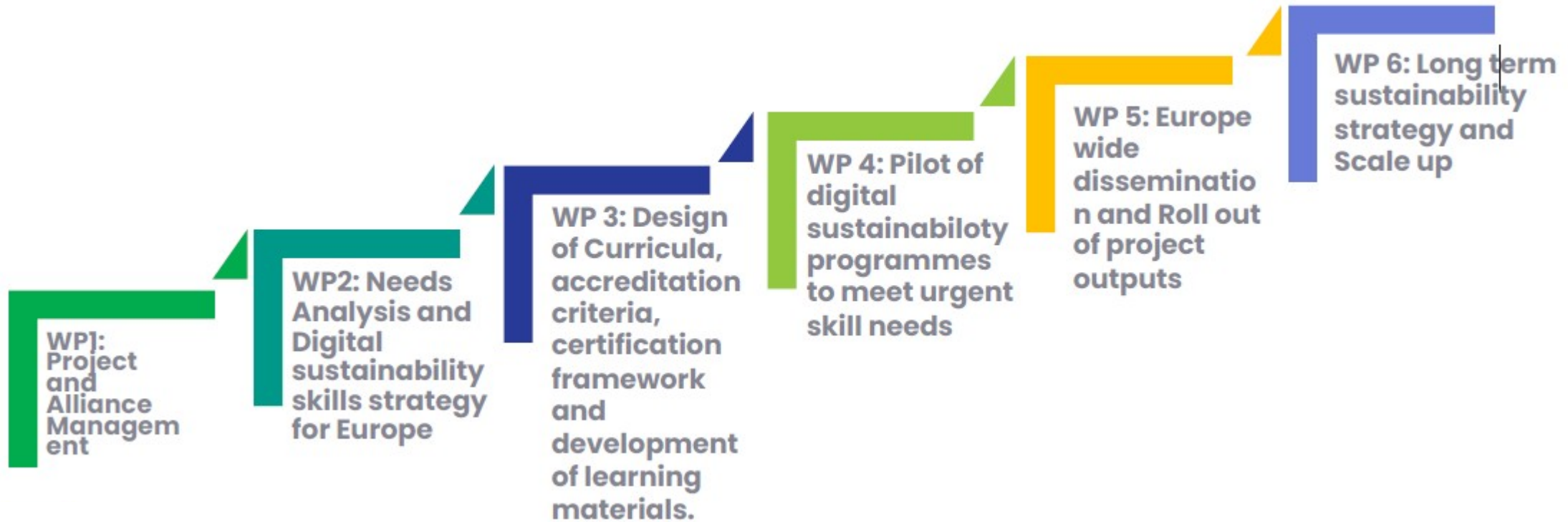

<https://digital4sustainability.eu/>



[About](#) [Partners](#) [News & Events](#)

[Get in touch](#)



Welcome to Digital4Sustainability

Empowering the European Workforce for the sustainable digital transition

[About us](#)





Meet the speaker

Dr. Roberto Moreno García

Profesor Asociado, UNIR

Agenda

1. Sustainability
2. Sustainable development
3. What is Digital Sustainability?
4. What is the relation between SDG and Digital Sustainability?
5. Advantages of Digital Sustainability
6. Digital Sustainability Strategies in Industry
7. Digital Sustainability Tools
8. Real case examples
9. Challenges and opportunities
10. The future



Digital Sustainability in Industry

Sustainability

- The viability of a system in all its social, economic and environmental components, throughout time.

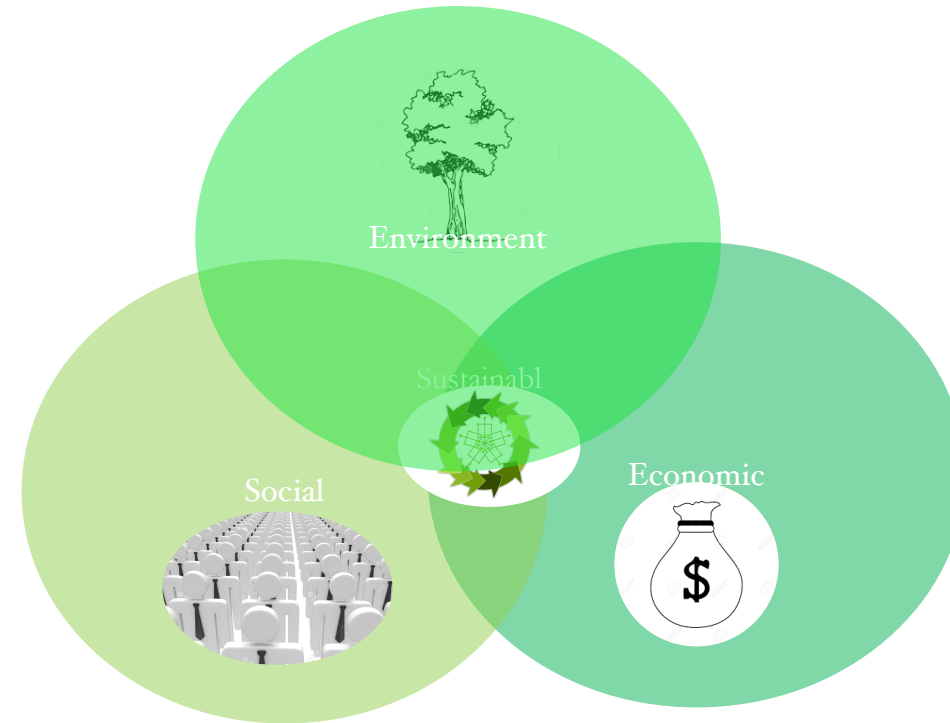

Sustainable development

- Sustainable development is defined as the development able to satisfy today's needs without affecting the capacity of future generations to satisfy their own needs.



What is Digital Sustainability?

- Create, use, manage digital resources with the aim to maximise their value for our society, today and in the future.
- Digital sustainability can be defined as the capacity of a digital system to stay active and continuously renovate.

What is Digital Sustainability?

- Integration of digital technologies in industrial processes
- Optimisation of resources and reduction of waste.
- Circular economy.



What is the relation between SDGs and Digital Sustainability ?

Digitalisation offers innovative solutions to face global challenges such as climate change, inequality and scarcity of resources. By integrating digital technologies in industrial production and in social processes, companies and governments can :

- Measure and monitor progress: Digital technologies allow collection and analysis of huge quantities of data, facilitating the achievement of the SDGs objectives and indicators and impact evaluation of policy initiatives and actions.
- Resource optimisation : Digitalisation can improve efficiency in the use of natural resources, energy and material, contributing to the SDGs related to the environment.

What is the relation between SDGs and Digital Sustainability ?

- **Enhance innovation:** Digital technologies promote innovation and development of sustainable solutions like renewable energy and smart agriculture and cities.
- **Widen access:** Digitalisation can improve access to key services like education, health and energy, especially in marginalised communities, contributing to reduce inequality
- **Promote collaboration:** Digital platforms facilitate collaboration among different actors like governments, companies and civil society to jointly face global challenges.

Digital Sustainability advantages

- Reduction of operational costs.
- Improved efficiency and productivity.
- Decreased energy and water consumption.
- Greenhouse gas emissions reduction.
- Increased market competitiveness .



Digital Sustainability Strategies in Industry

- **Ecological product design:** Encourages the creation of durable, repairable and recyclable products.
- **Process optimisation:** implements digital tools to improve efficiency and reduce waste.
- **Use of renewable energy:** encourages the adoption of clean energy in industrial processes.
- **Responsible data management:** Stores and processes data efficiently and securely.



Tools for Digital Sustainability

- **IoT (Internet of Things):** Real time monitoring of industrial processes, Digital Twins.
- **Artificial Intelligence:** Supply Chain Optimisation and predictive maintenance.
- **Big Data:** Analysis of huge volumes of data to take more informed decisions.
- **Robotics:** Automatisation of dangerous and repetitive tasks.



Sustainability Implementation

- **Manufacturing Industry:** Optimise production processes, reduce energy and materials consumption, improve waste management.
- **Energy sector:** Promote the generation of renewable energy, improve electricity grids' efficiency and develop energy storage solutions.



Sustainability Implementation

- **Construction:** use of sustainable material, optimisation of construction processes and reduction of energy consumption in buildings.
- **Transport:** Electric vehicles production, optimisation of transport routes and promotion of sustainable mobility



Examples



- **Nestlé:** implemented digital technologies to optimise its supply chains, reduce food waste and improve the traceability of their products.
Ha implementado tecnologías digitales para optimizar sus supply chains, reduce food waste and improve the traceability of their products.
- **Siemens:** developed digital solutions for energy efficiency in buildings and industry and for electric mobility.
- **Unilever:** established ambitious sustainability targets and is using digital technologies to reduce its environmental footprint across the value chain.

Challenges and Opportunities



- **Challenges:** Initial investment, resistance to change, lack of digital skills
- **Opportunities:** Improved brand image, access to new markets, compliance with environmental regulations. Sustainability

The future



- Vision of a completely digitalised and sustainable industry.
- Key role of collaboration among companies, governments and academia.



Meet the speaker

Dr. Iván Peña

Coordinador Académico UNIR

DT and MSBE: What Digital Twins Are and What They Are Not

Contents



Definition



Components



Advantages



Challenges



Return on Investment

What are Digital Twins (DT)?

Digital Twins are entities with their own **unique nature**.

This technology is increasingly adopted by organisations to enhance their **product** and **service** portfolios as well as their **operations**.



Thanks to the **sensorisation** of their **functional and health** status variables.

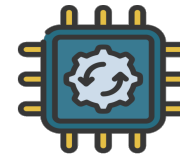

These types of deployments enable the **evolution** towards **intelligent** systems that learn thanks to the sensorisation of their functional and health state variables.



Ultimately, they lead to **autonomous systems** for specific functionalities.



Additionally, they can be deployed or **integrated** into the **real** product, creating a **cyber-physical** system that **combines how it should** behave with **how it actually behaves**.



They **virtually represent and simulate** **real** entities so that their behaviour or **response to certain conditions can be predicted**.

*“Industrial sectors require **experts** to lead the implementation of digital twins to help them improve their products, optimise their processes and **enable new customer services.**”*

What is a Digital Twin (DT)?

It is an accurate virtual replica connected to its physical counterpart and synchronised to provide added value to the system.

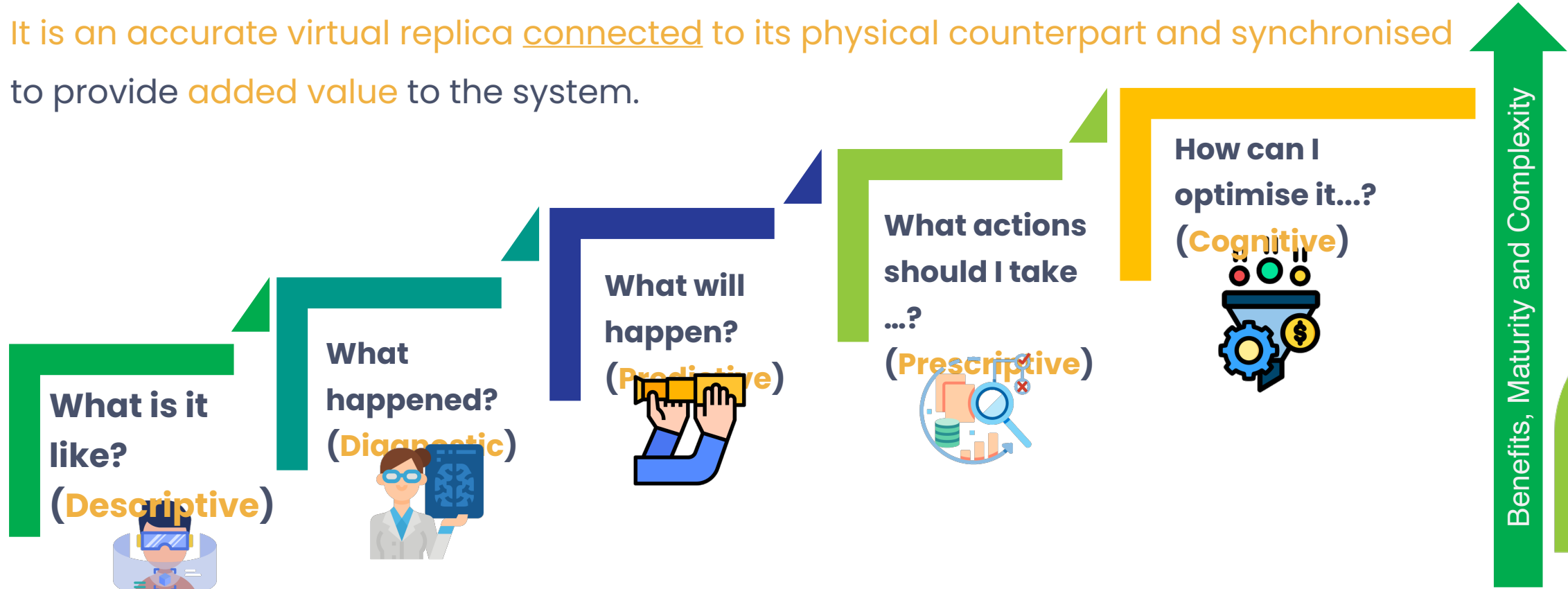

Challenges

Identifying the functionalities to start with

And demonstrate the return on investment

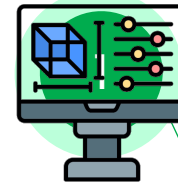

Models

Development of increasingly sophisticated multiphysics simulation models

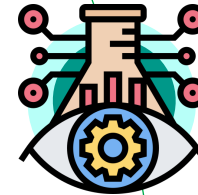

Hybridisation

Synthesis of models from data and hybridisation with physics-based models



Data and configuration

Management of hardware and software configuration



Backbone

A robust environment for development, execution and sustainment



Human-Machine Interface

Adequate human interaction to simplify user experience

Advantages of Digital Twins

- Anticipating and helping the person



Model management - throughout the life cycle

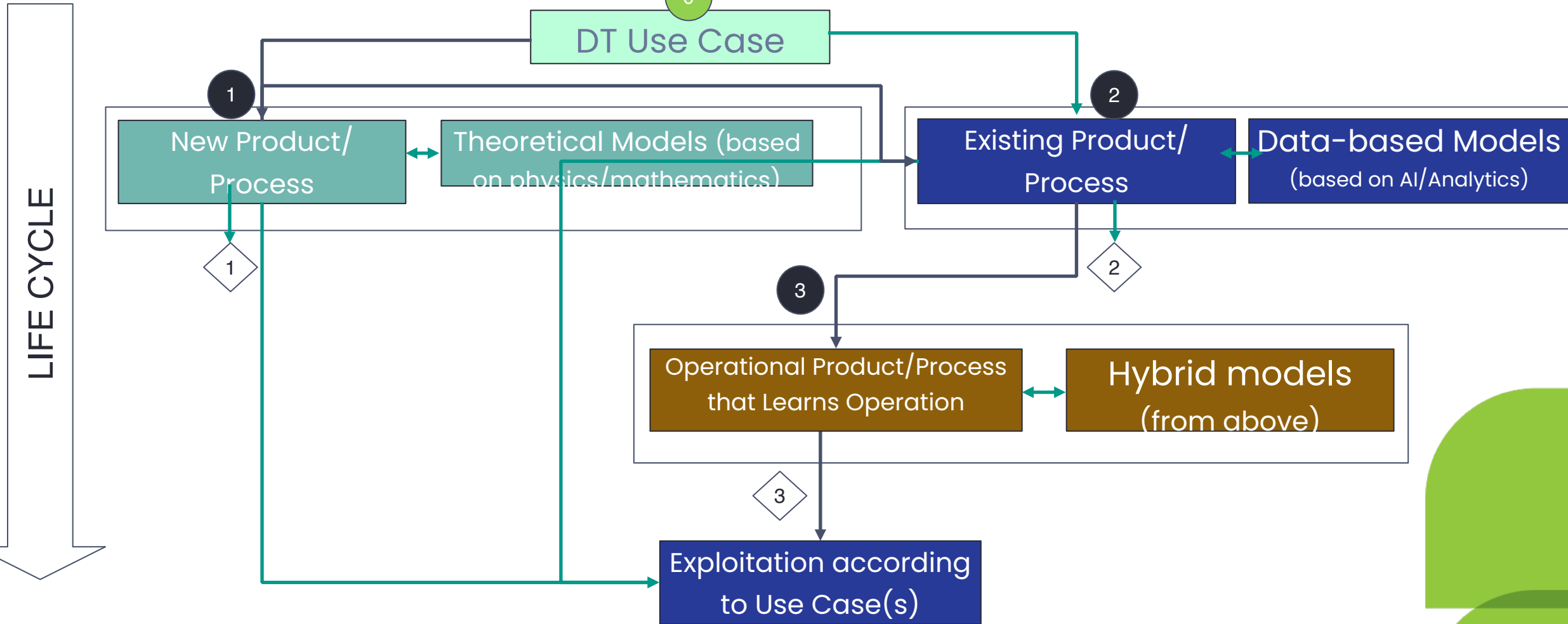

Value of Digital Twins (DT) - Applications

Once the data has been processed, the virtual model can be used to run simulations, study performance issues and generate potential improvements. **The goal is to generate valuable insights that can then be applied back to the original physical object.**

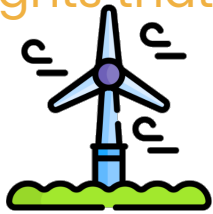

Power
generation
equipment

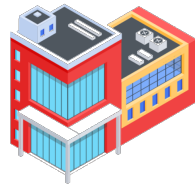

Structures
and their
systems

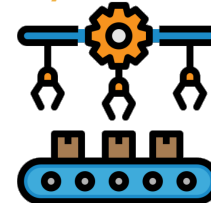

Manufacturing
operations

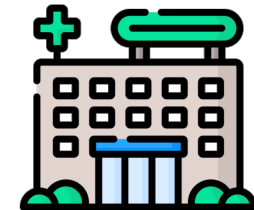

Healthcare
services

Realisation of a Digital Twin (DT)

The **virtual representation of a real asset** is materialised in a **set of models and their exploitation applications**, typically consisting of a **front-end** adapted to human interaction and a **back-end** with the appropriate software for the use case.

This **set of elements and software components** is executed on a computing, storage and information **exchange infrastructure in the form of a digital platform**.

The **connection of this replica with the real asset in a bidirectional manner** requires the use of **sensors and actuators**, with the former gathering information from the real world and the latter incorporating information from the **Digital Twin for the optimisation of the**

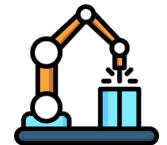

Digital Twins - IoT/Ind4.0 Differences

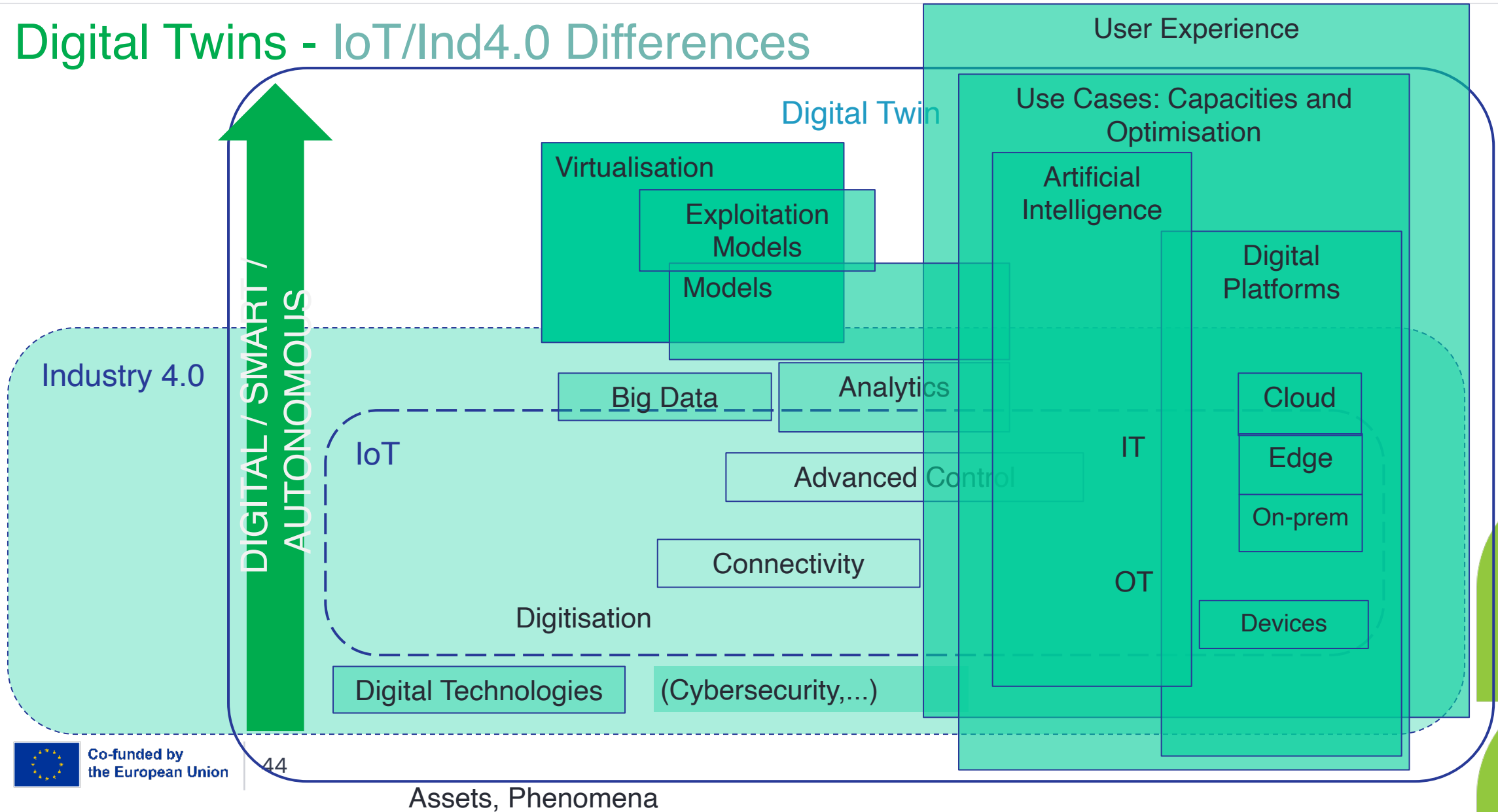

Overview of the Architecture

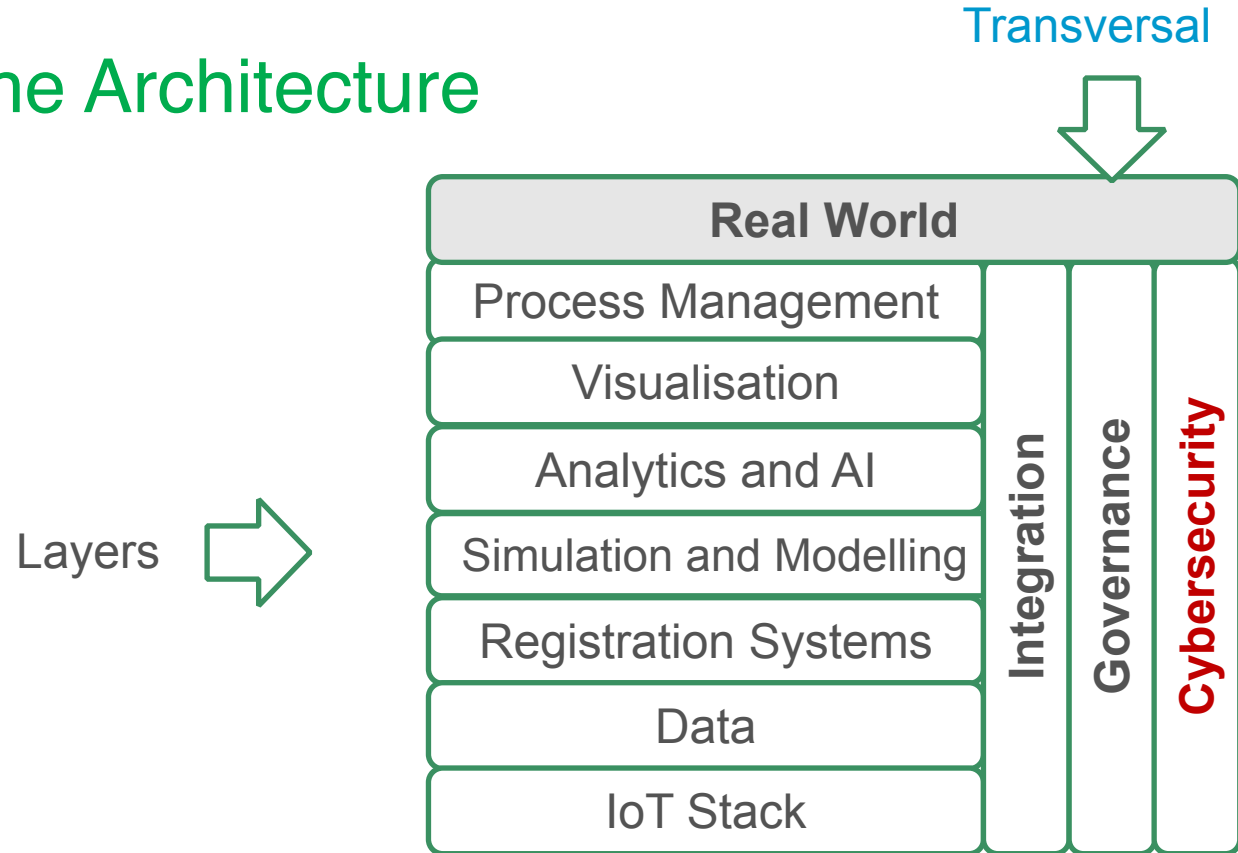

Contents



Definition



Components



Advantages



Challenges



Return on Investment

CALCULATION

$$\text{ROI} = \frac{\text{INCOME} - \text{INVESTMENT}}{\text{INVESTMENT}} \times 100$$

TOTAL INCOME	€46,500 K
--------------	-----------

TOTAL EXPENDITURE	€36,100 K
-------------------	-----------

ROI = 28.8%

We do not have income from maintenance, nor from app maintenance.

Each year we recover 28.80% of the initial investment, i.e. €13,396,121.
It will take 3.5 years to recover the full investment.

ORIGINAL CONTRACT - Revenues and expenditures are focused on the initial phases of the project



The contractual relationship ends with the delivery of the product

	Contract	Development	Delivery	Life Cycle
Products				
Digitisation	8,500 K	17,000 K	21,000 K	
Applications				
DT maintenance				
	8,500 K	17,000 K	21,000 K	

INCOME = €46,500 K

	Contract	Development	Delivery	Life Cycle
Design and development	4,054 K	8,107 K	4,054 K	
Deployment	2,461 K	4,923 K	2,461 K	
Operation and maintenance	250 K	500 K	250 K	
Digital add-ons	2,210 K	4,420 K	2,210 K	
Licences	50 K	100 K	50 K	
	9,025 K	18,050 K	9,025 K	

EXPENSES = €36,100 K€

Return On Investment

$$ROI = \frac{INCOME - INVESTMENT}{INVESTMENT} \times 100$$

IF THE RETURN ON INVESTMENT IS **LESS** THAN 100%

The investment is not fully recovered in the first year. The percentage indicates how much you earn of the amount you primarily invested, and therefore, how many years it will take to recover it.

IF THE RETURN ON INVESTMENT IS **GREATER** THAN 100%

The full investment is recovered from the first year, and the result obtained reflects the cash surplus generated by the investment.

DEVELOPMENT DURING OPERATION - The income and expenses are sustained throughout the life cycle

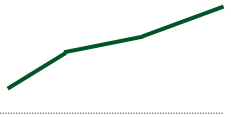

	Contract	Development	Delivery	Life Cycle
Products				
Digitisation	5,125 K	6,500 K	5,500 K	
Applications				10,000 K
DT maintenance				13,675 K
	5,125 K	6,500 K	5,500 K	23,675 K

INCOME = €46,500 K

	Contract	Development	Delivery	Life Cycle
Design and development	1,621 K	6,486 K	3,243 K	4,864 K
Deployment	985 K	3,938 K	1,969 K	2,954 K
Operation and maintenance	100 K	400 K	200 K	300 K
Digital add-ons	884 K	3,536 K	1,768 K	2,652 K
Licences	20 K	80 K	40 K	90 K
	3,610 K	14,440 K	7,220 K	10,860 K

EXPENDITURE = €36,130 K

CALCULATION

$$\text{ROI} = \frac{\text{INCOME} - \text{INVESTMENT}}{\text{INVESTMENT}} \times 100$$

TOTAL INCOME	€40,800 K
TOTAL EXPENDITURE	€36,130 K
ROI = 12.92%	

In this case, we will have income from the maintenance of the DT and from applications.

Each year we recover 12.92% of the initial investment, i.e. more than €5,273,623. It will take a little over 8 years.

CONCLUSIONS

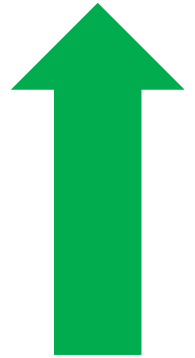

Original
contract

On the other hand, when the contractual relationship ends with the delivery (**ORIGINAL CONTRACT**), the investment takes **fewer years to recover**, since the client pays the full price before the delivery, but the **contractual relationship** ends there. Another important point to highlight is the earlier **obsolescence** of the product, as it is a product with a long-life cycle and would not be updated.



Development
during operation

Maintaining the contractual relationship for more years (**DEVELOPMENT DURING OPERATION**) means the investment takes **longer to return**, but it can **lead to the signing of more contracts**, keep workers for a longer time and **create** a sustained

Future of Digital Twins [4]

The operational models of companies and institutions are changing disruptively (Digital Transformation), and the **digital reinvention** in industries with large assets **requires an integrated physical and digital view of the assets, teams, facilities, and processes.**

Digital twins are a vital part of this realignment.

The **future of digital twins is almost limitless**, due to the fact that increasing amounts of cognitive power are constantly being dedicated to their use. Therefore, **digital twins are constantly learning new skills and capabilities, which means they can continue to generate the necessary information to improve products and make processes more efficient.**



Meet the speaker

Carlos Rodríguez Alonso

Specialist in GD at Ayesa
Engineering and Architecture

www.linkedin.com/in/carlosrdzalns

Digital Twins in a water treatment plant

Agenda

1. Introduction
2. Public tenders
3. Digitisation strategy
4. Digital Twin Platform - Wastewater treatment plant
5. Conclusions
6. Q & A



Introduction

Digital Twin

A Digital Twin is a virtual replica of a physical system, fed with performance, maintenance, and health information of the real system, keeping it updated throughout the entire life cycle, with the goal of using technologies such as Artificial Intelligence, Simulation and Modelling or Virtual Reality to improve decision-making and generate value.

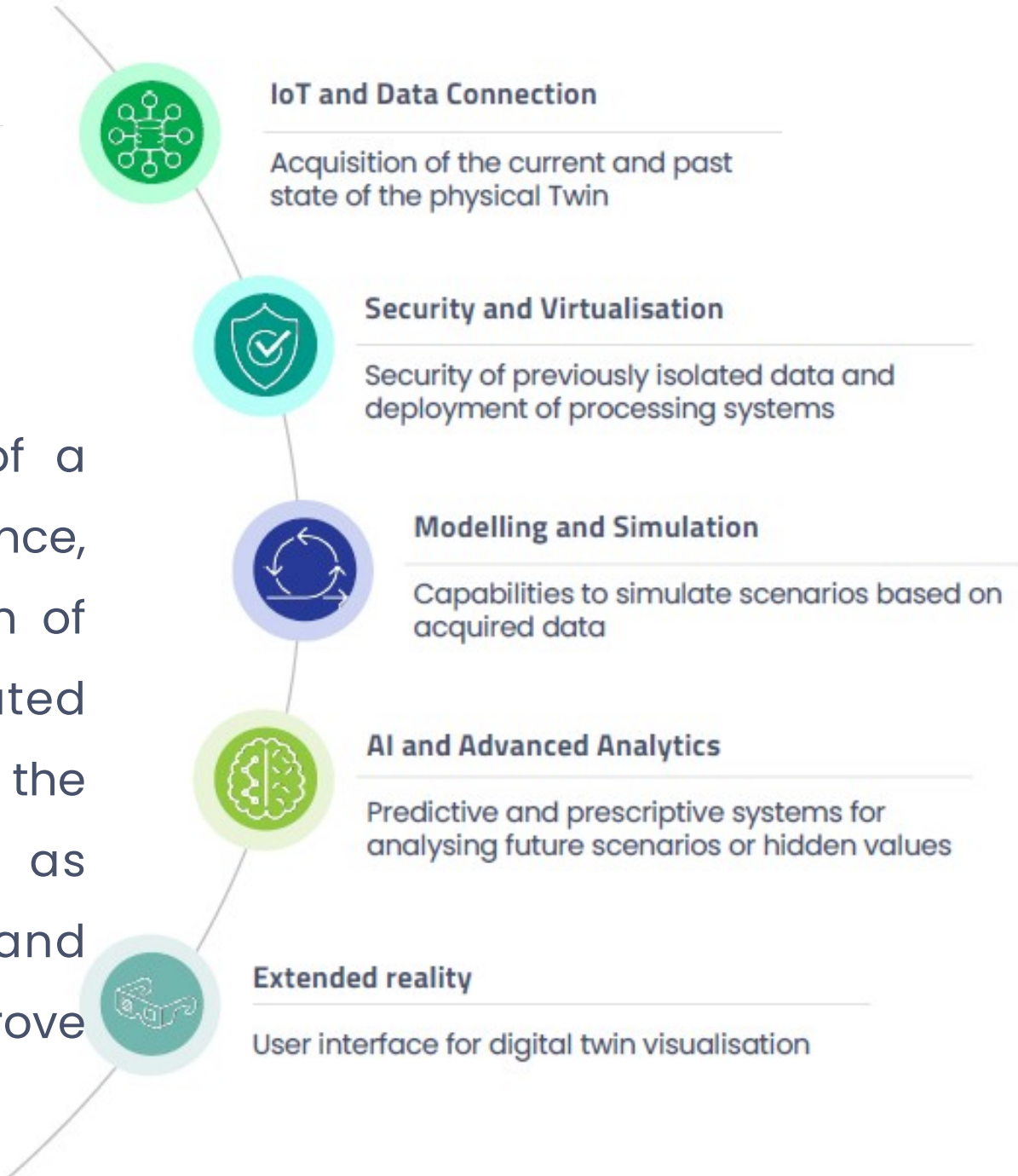

DT Maturity

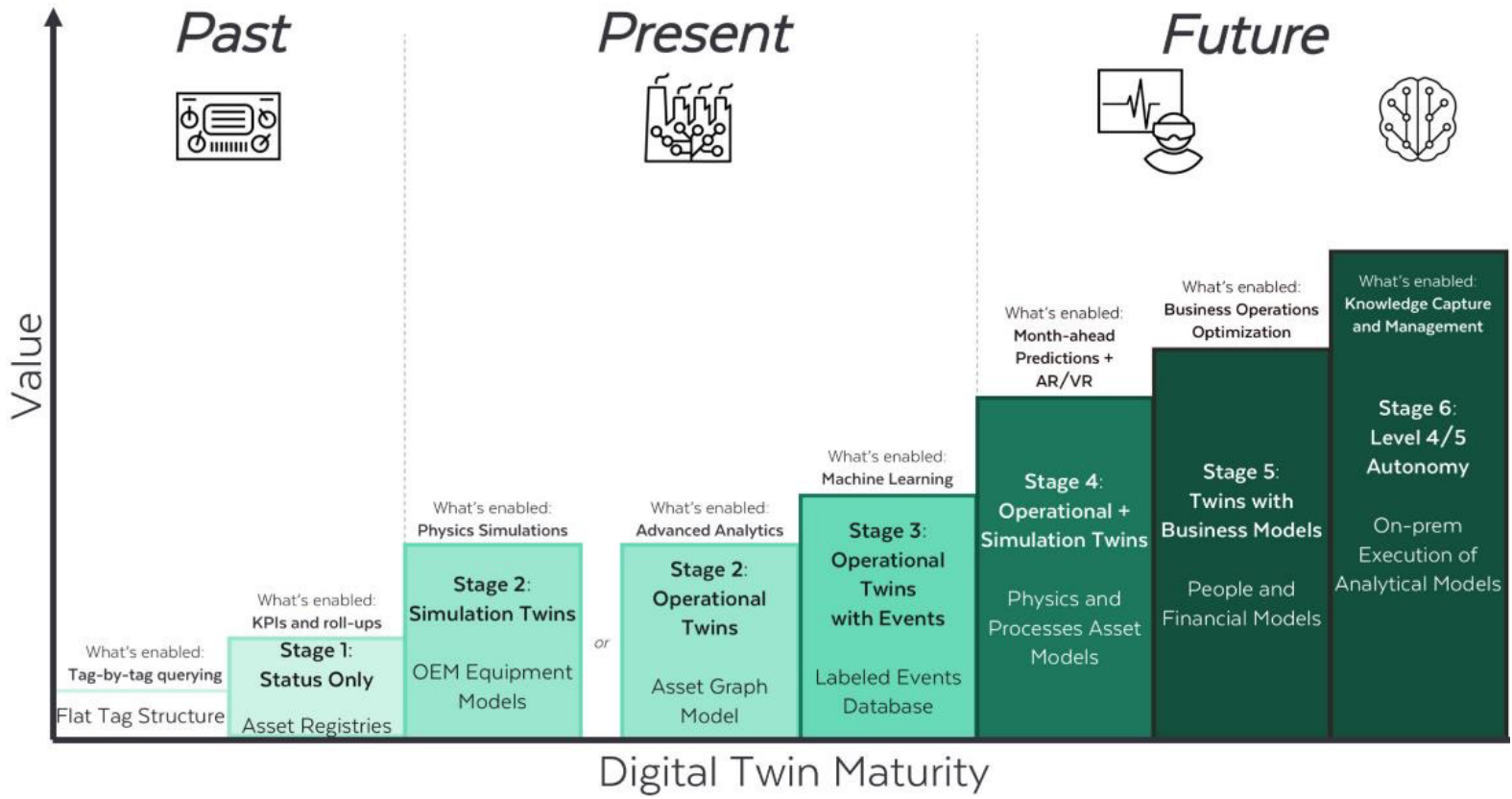

- Stage 1: State Digital Twin.
- Stage 2: Operational Twin/ Simulation Twin
- Stage 3: Operational Twin with Events
- Stage 4: Operational and Simulation Digital Twin
- Stage 5: Digital Twin with business information

Digitisation Strategy and Digital Twin

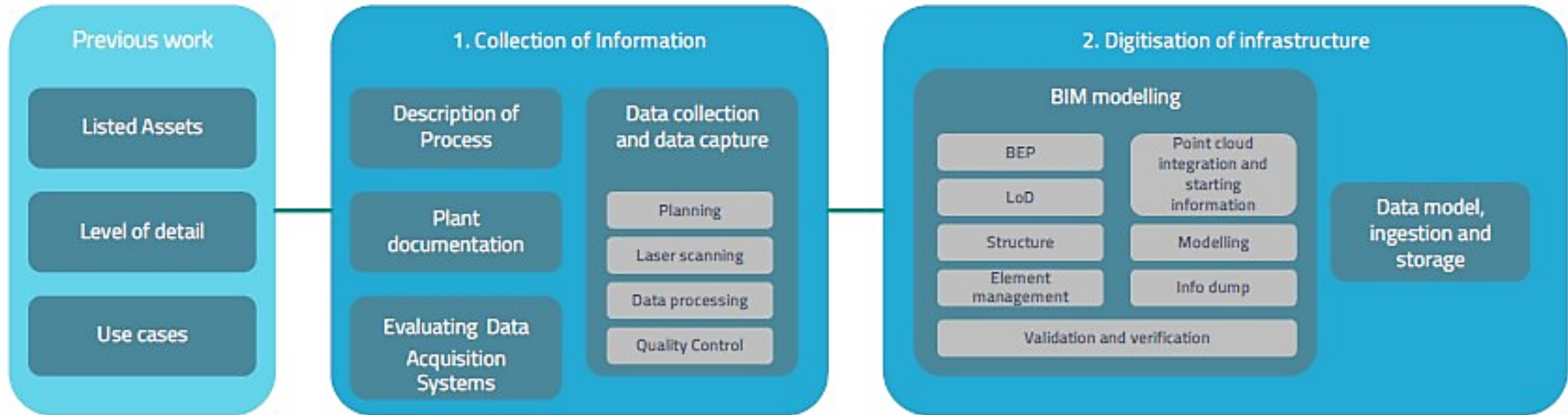

Digitisation Strategy and Digital Twin

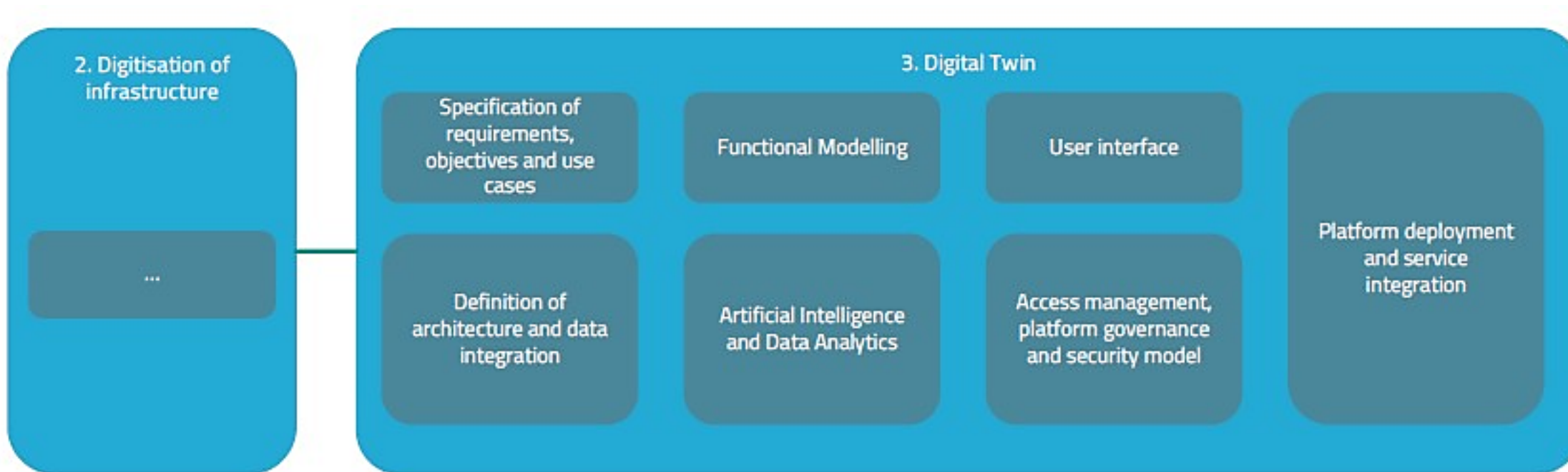

Digitisation Strategy and Digital Twin

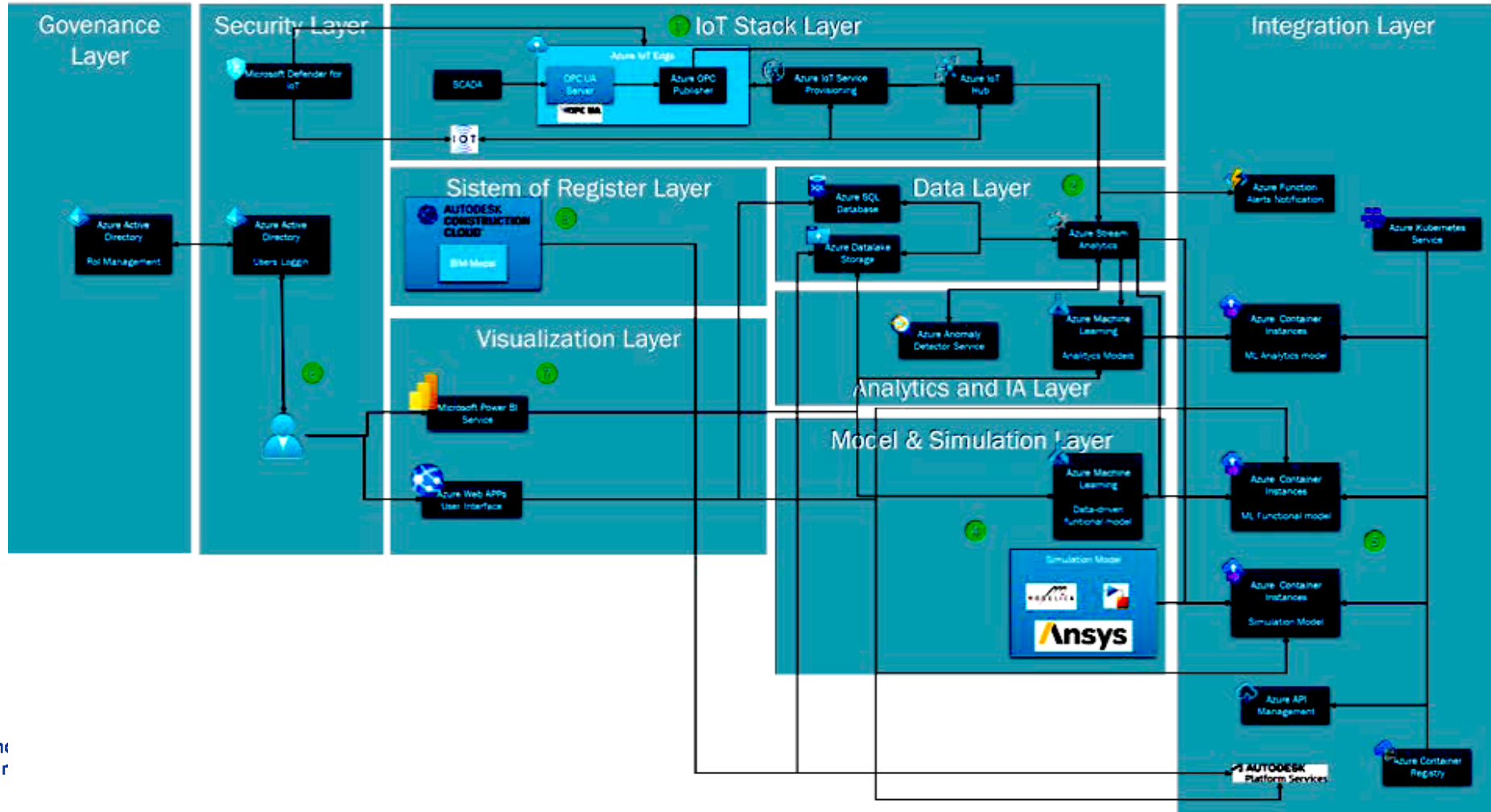

Digital Twin Platform – Urban wastewater treatment plants

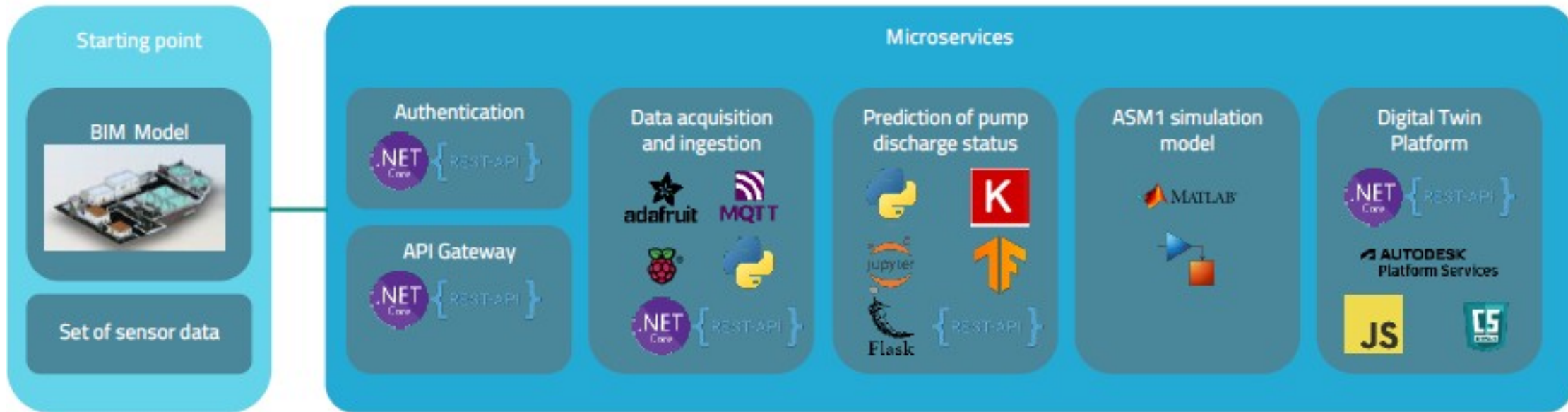

Digital Twin Platform – Urban wastewater treatment plants: Architecture

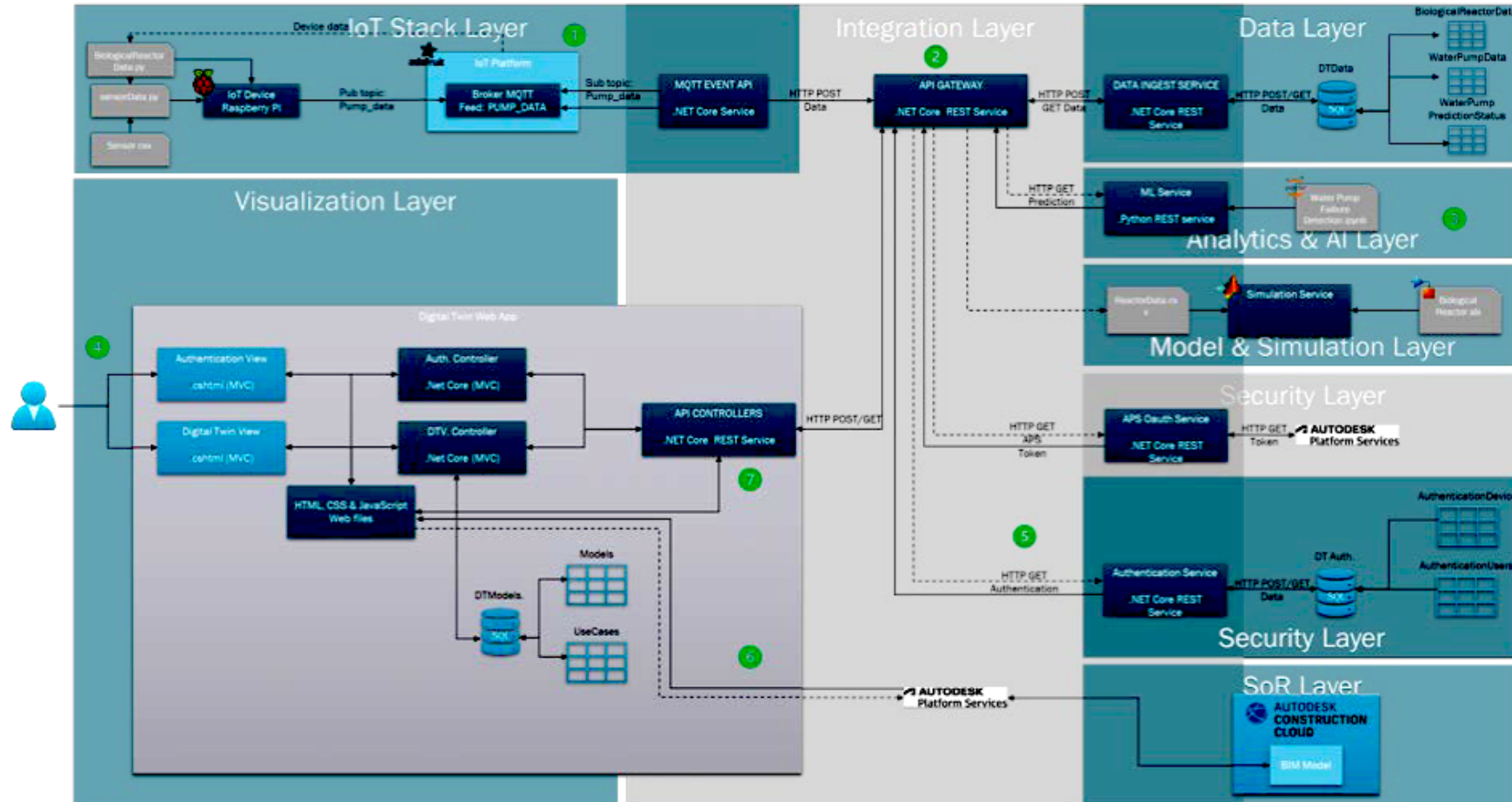

Digital Twin Platform – Urban wastewater treatment plants: Models

ML Model: Statement of assets

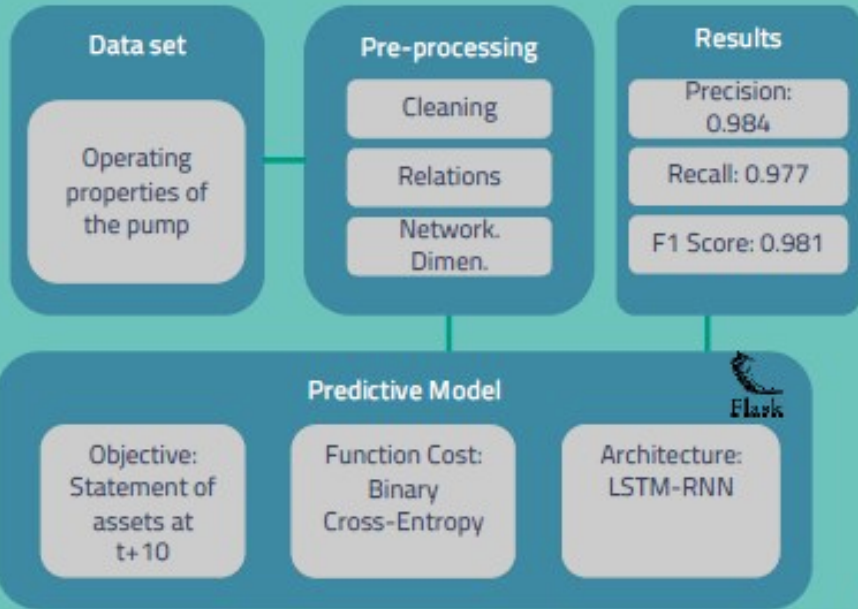

Biological Reactor Simulation Model

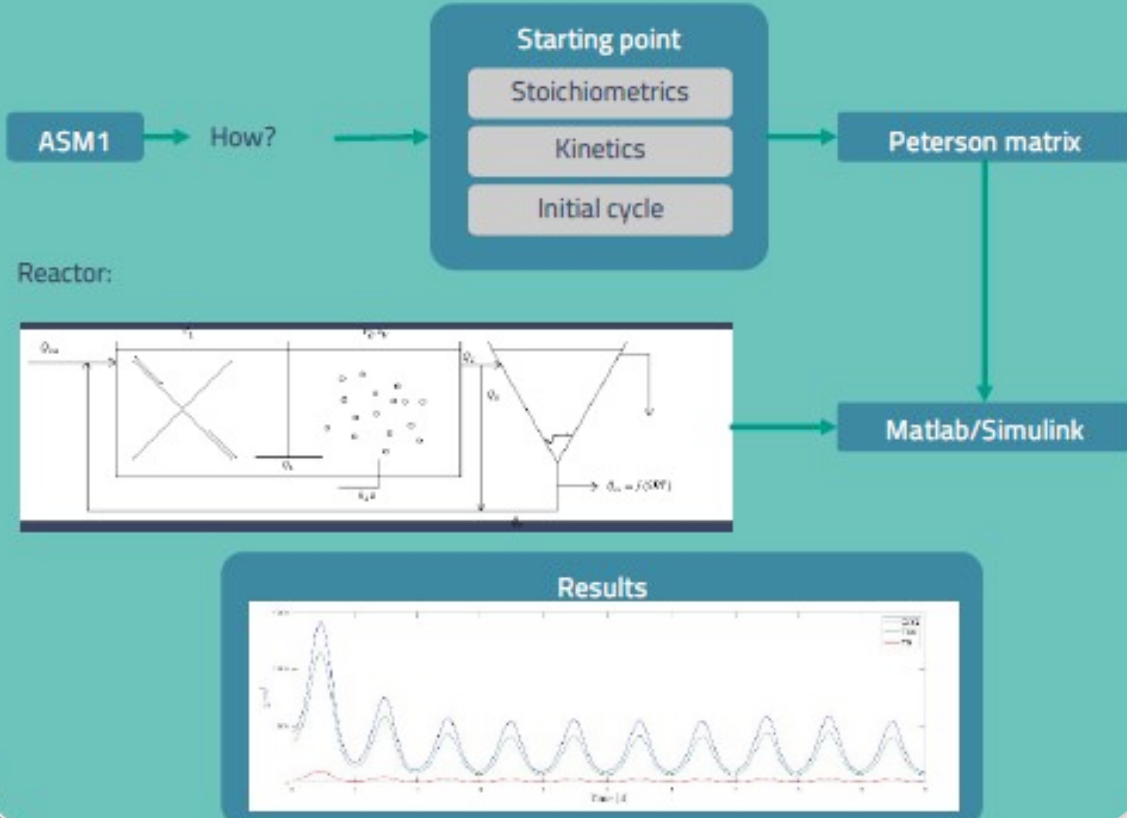

Digital Twin Platform – Urban wastewater treatment plants: Web Platform



Conclusions

Benefits:

- Process optimisation and cost reduction
- Demand predictions
- Predictive maintenance
- Control and prescriptive design
- Detection of anomalous situations

Challenges

- Technological maturity
- Confidence in results
- Organisation-led transformation
- Investment



Meet the speaker

Carlos Real Gutiérrez

PDI University of Cantabria

Digital Twin for Additive Manufacturing Processes of Mortars

Agenda

1. Introduction and context
2. Current limitations
3. Digital Twin based solution
4. Process control models
5. Conclusion and call for action



Introduction and context

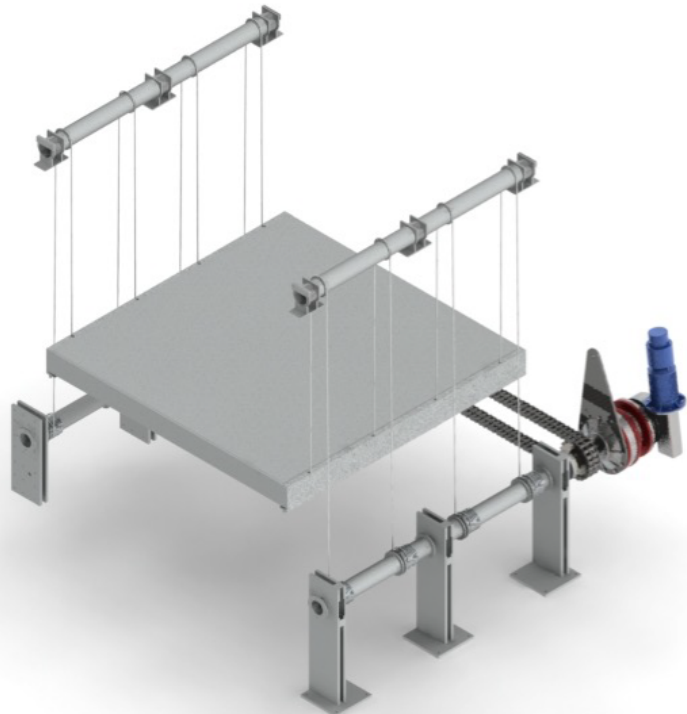

2015

We began working with D-Shape 3D printing technology

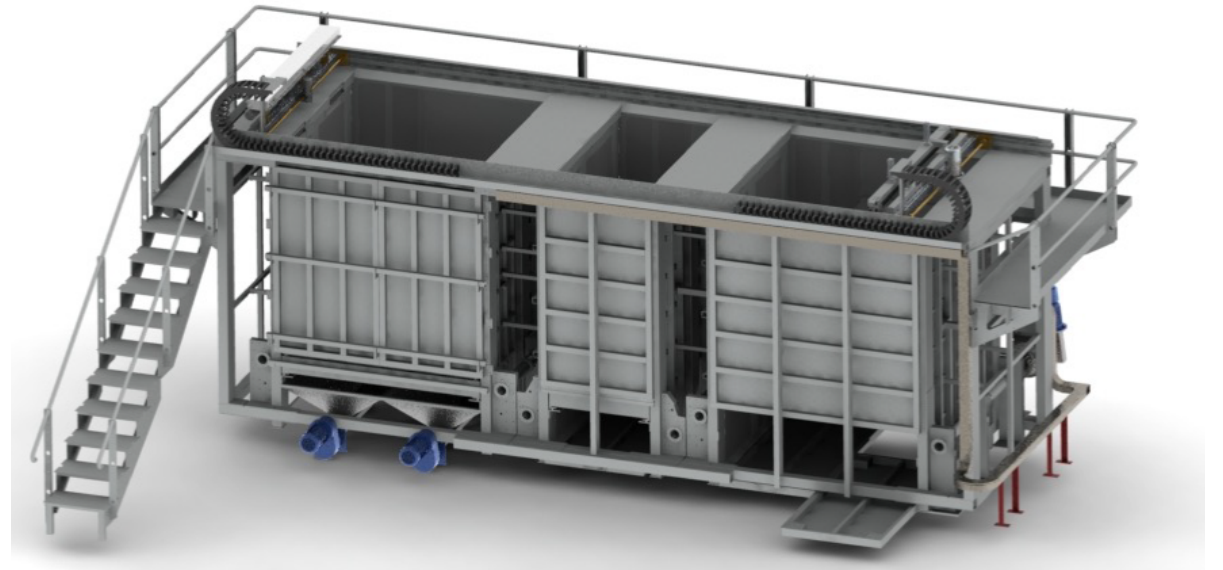

- Irregular setting times
- Lack of cohesion in the printed structure
- High porosity
- Low resistance to mechanical stresses
- Limitations in dimensional accuracy
- Need for additional finishing processes

ISSUES

Introduction and context

2017 – We adopted Concrete Printing technology

This technology offers significant advantages in terms of **design flexibility, efficiency** and **cost reduction**.

Delta-type
Printer
from Wasp
Iberia
Model: **WASP**



ISSUES WITH THE DELTA PRINTER

- Difficulty in controlling mortar viscosity
- Limited control over the flow rate
- Rigidity of the delta structure, which is more limited in terms of width
- Printing only on horizontal blueprints
- Frequent maintenance required due to head clogging

Current limitations

MAIN LIMITATIONS

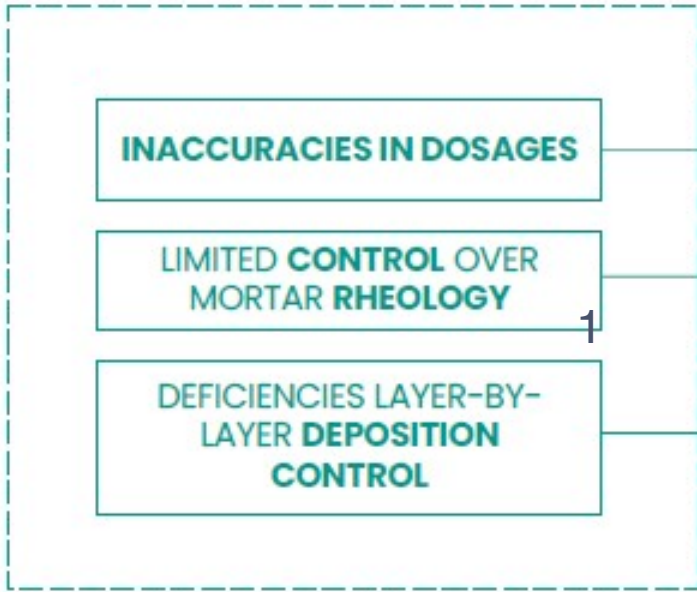

POSSIBILITIES FOR IMPROVEMENT

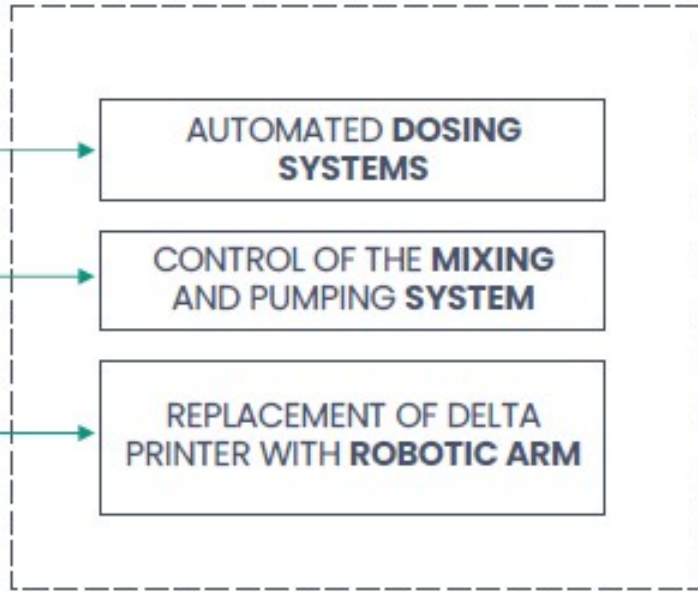

DIGITAL TWIN

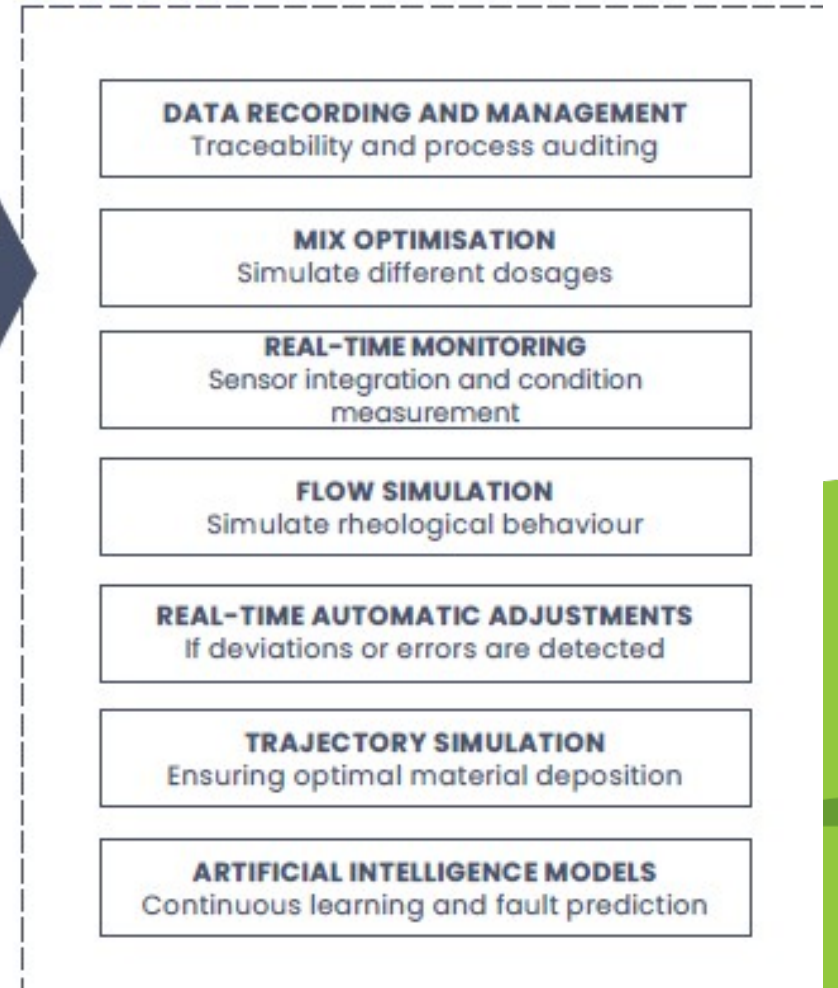

- 1 - Automated dosing systems
- 2 - Mixing and pumping systems
- 3 - Robotic arm



Digital Twin based solution

MAIN OBJECTIVE

Implement a **new technology based on Digital Twin** that allows us to achieve greater control over the **additive manufacturing** processes of **mortars**.

Speed, precision and quality of the final product

What does a Digital Twin offer us?

1. **Data recording**
2. Real-time **monitoring**
3. **Simulation** of operations
4. Continuous learning



Co-funded by the European Union

What does a Digital Twin offer us?

Developing materials and optimising the process

Digital Twin based solution

It is essential to ensure **optimum rheological behaviour** of the mortar
It must **flow** during the extrusion process and, once in place, quickly **regain**
its **viscosity and rigidity**

AI MODEL

Predicting the mechanical
behaviour of the mortar

RHEOLOGICAL MODEL

Determining the rheological
behaviour of the mortar

The **quality of the mortars** is
essential to ensure and control the
structural integrity and precision of
the printed objects.

**Rheology and the control of
thixotropy**, a viscoelastic property
that affects the **fluidity and**

Digital Twin based solution

ARCHITECTURE

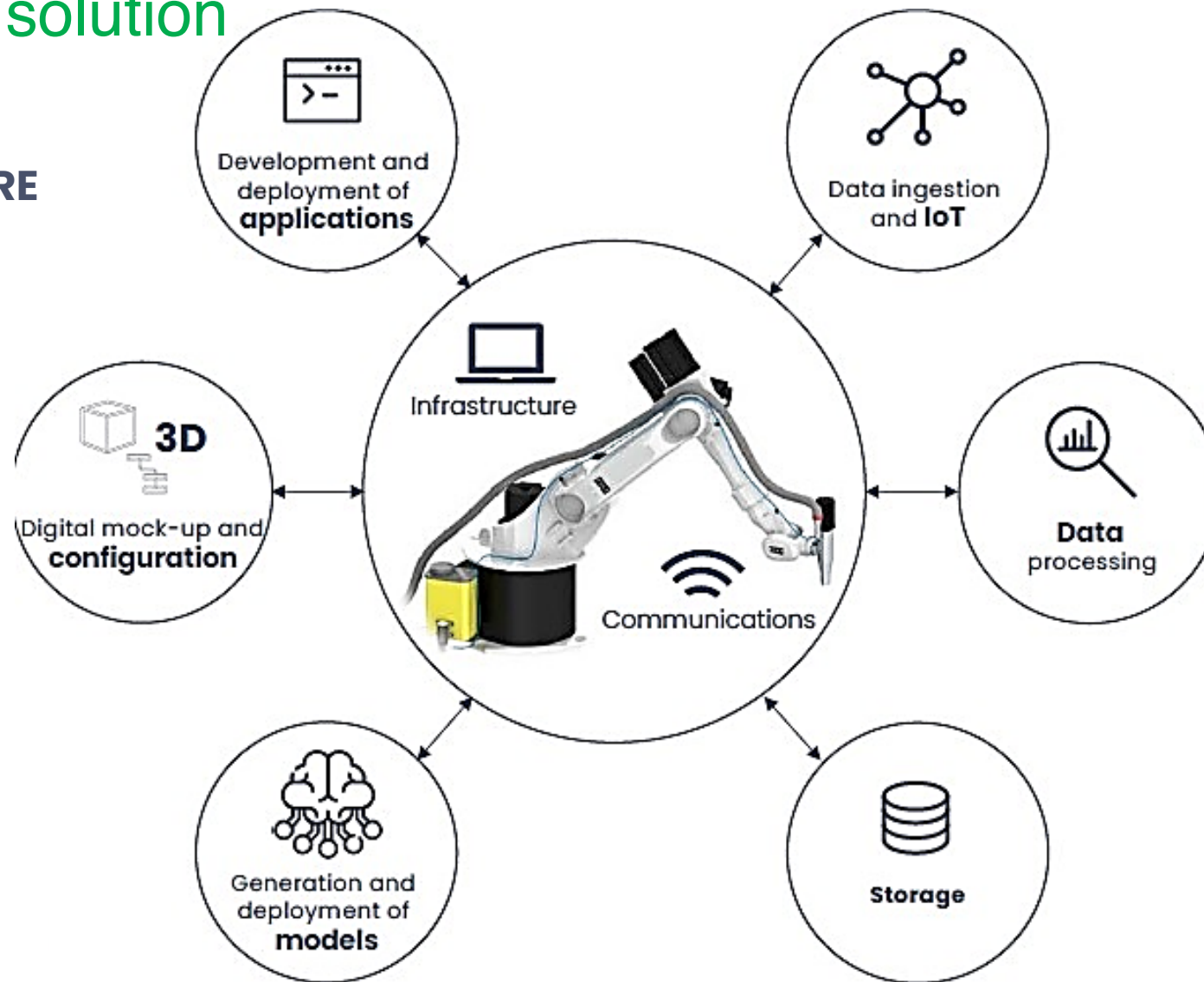

Digital Twin based solution

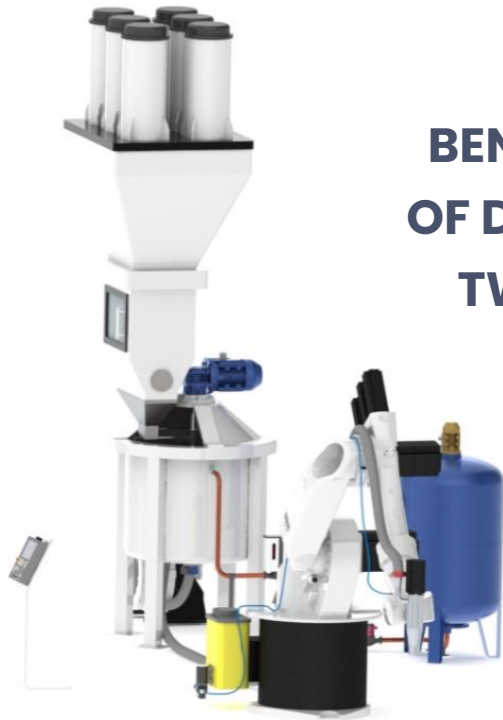

BENEFITS OF DIGITAL TWINS

SIMULATION OF MORTAR PROPERTIES

Simulating how different mortar formulas will behave in the printing process. **Optimising the development of mortars**

PERFORMANCE PREDICTION

Predicting the **strength, fluidity and stability** of each mix

REDUCTION OF DEVELOPMENT TIME AND COSTS

Simulating different formulas and properties helps **minimise physical testing**

ADJUSTMENT OF PRINTING PARAMETERS

Speed, pressure and material flow are key to achieving the best print quality

REDUCTION OF ERRORS AND DEFECTS

Predicting deformations or adhesion problems of the mortar in different layers

Process control models

Objective: to predict the mechanical behaviour of the mortar based on the historical dosing data.

Purpose: to determine whether the mortar will meet the design requirements of the project, including flexural strength and compressive strength.

Data: the starting data includes the historical dosing records of mortars and the results from compression and flexural tests of those doses.

Models: a comparison is made between 3 regression models to predict the strengths at 28

AI MODEL
Predicting the mechanical behaviour of the mortar

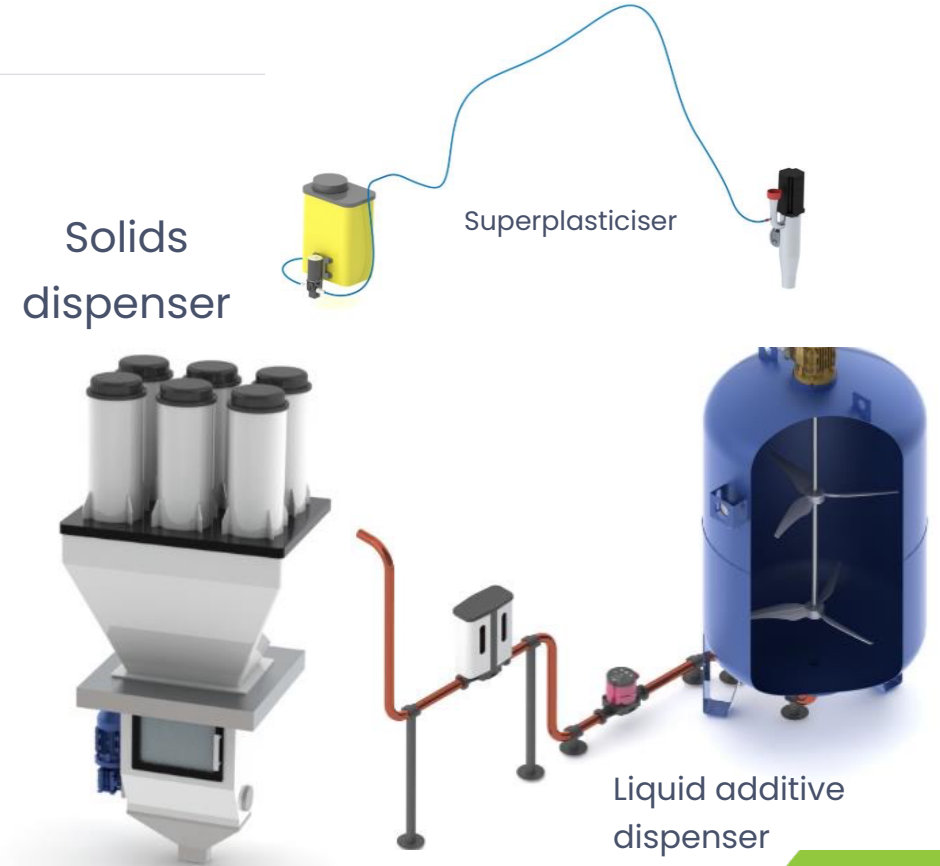

AI algorithms

Linear Regression with L2 regularisation (Ridge)

Random Forest

Support Vector Regression (SVR)

Process control models

Objective: to control the rheological behaviour of the mortar from mixing to deposition.

Purpose: to maintain thixotropic conditions. The mortar behaves fluidly when subjected to agitation and recovers viscosity when the applied force stops.

Data: to adjust the mathematical models, ramp tests are used.

A method in which a deformation or stress rate is applied to the mortar that changes linearly over time.

Models: rheological models are used to calculate

RHEOLOGICAL MODEL

Determining the rheological behaviour of the



Rheological Models

- Bingham Model
- Herschel-Bulkley model
- Houska's structural model

Challenges and Future Developments

Digital Twins are an ideal tool for **virtually replicating the behaviour** of the 3D printer and its associated processes, **facilitating analysis**, optimisation, and **real-time control** without the need to interrupt physical operations, which significantly accelerates the research and innovation cycle



ARTIFICIAL VISION

Development of defect detection systems, failure analysis or control of uniformity between layers.

STRUCTURAL STRENGTH SIMULATION

Optimisation of designs, simulation of material behaviour, and long-term performance predictions for the structure.

OPTIMAL TRAJECTORY

Development of dynamic adjustment models to adapt to rheological behaviour

Thank you for your time

Disclaimer

Funded by the European Union. Views and opinions expressed are however those of the author(s) only and do not necessarily reflect those of the European Union or the European Education and Culture Executive Agency (EACEA). Neither the European Union nor EACEA can be held responsible for them.

Copyright © 2024 Digital4Sustainability. The resources contained herein are publicly available under the Creative Commons license 4.0 B.Y.



Co-funded by
the European Union